

plausibilisierter Grundriss

Erstellt von

Carsten Rauh Sachverständiger

Erstellt am/Aufmass vom:

03.12.2024

Standort

60326 Frankfurt, Bischhofsheimer Straße 9

Objektart: Reihenendhaus

Lage der Einheit: links

Wohnfläche

100,51 m²

Erstellt und geprüft

Carsten Rauh

Sachverständiger für Immobilien und Bauwesen

HYPZert zertifiziert gemäß § 24 BelWertV

Sophienruhe 2

D-65812 Bad Soden

Tel: +49 (0) 163 6967699

Mail: info@sv-rauh.de

www.sv-rauh.de



Bad Soden den 04.12.2024

Anmerkungen:

Die im Grundriss angegebenen m² (in den Räumen) können zur Wohnfläche abweichen. Gültig ist die gesondert, beigefügte, plausibilisierte Wohnflächenberechnung nach DIN 277 oder WoFIV/Wohnflächenverordnung.

Haftungsausschluss

Die erstellten Grundrisse sind keine Konstruktionspläne. Es können Abweichungen, resultierend aus Behinderungen beim Aufmaß, der örtlichen Gegebenheiten und der genutzten Soft- und Hardware auftreten. Die im Grundriss ausgewiesenen Wohnflächen sind keine DIN Berechnungen. Für Abweichungen wird keine Haftung übernommen.

▼ Kellergeschoss

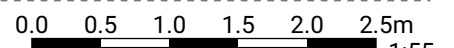
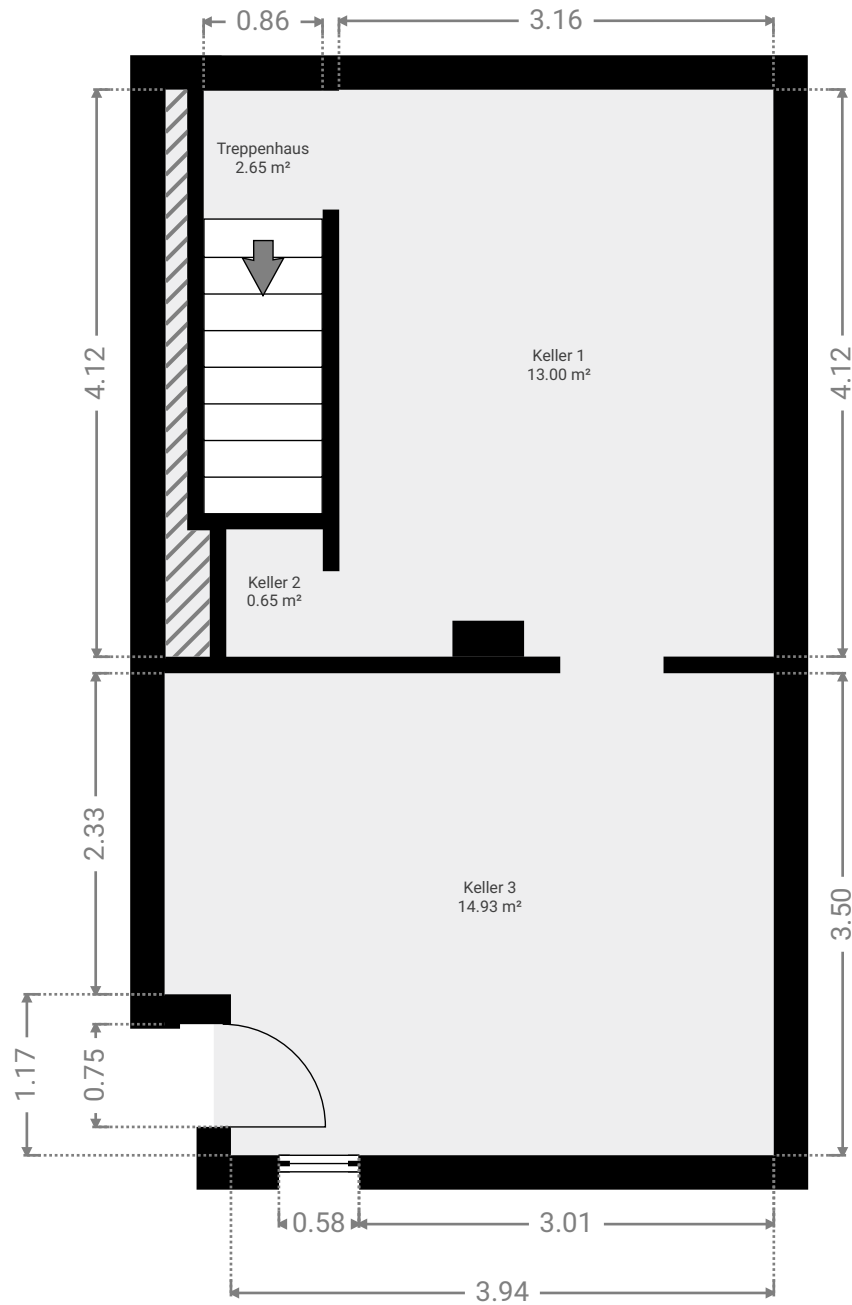

▼ Keller 1
Kellergeschoss

BREITE: 3.16 m · LÄNGE: 4.12 m
BEREICH: 13.00 m² · UMFANG: 14.55 m

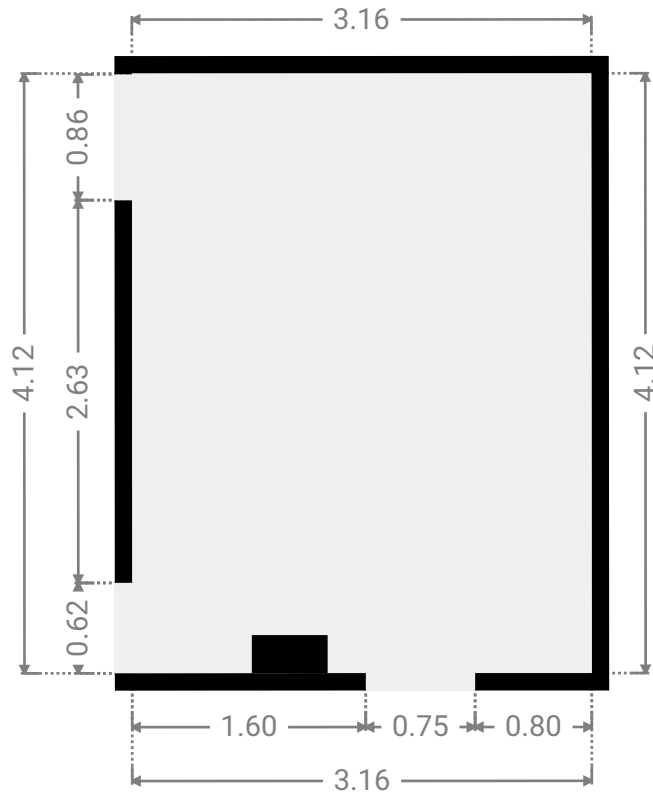
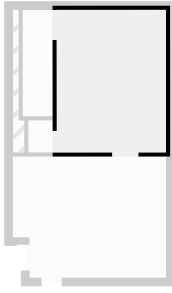

▼ Keller 2
Kellergeschoss

BREITE: 0.70 m · LÄNGE: 0.92 m
BEREICH: 0.65 m² · UMFANG: 3.25 m

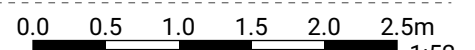
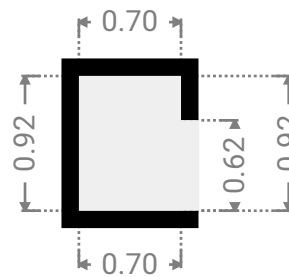
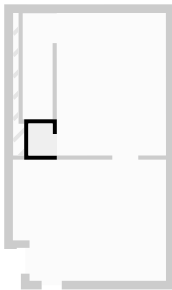

▼ Keller 3
Kellergeschoss

BREITE: 4.43 m · LÄNGE: 3.50 m
BEREICH: 14.93 m² · UMFANG: 15.85 m

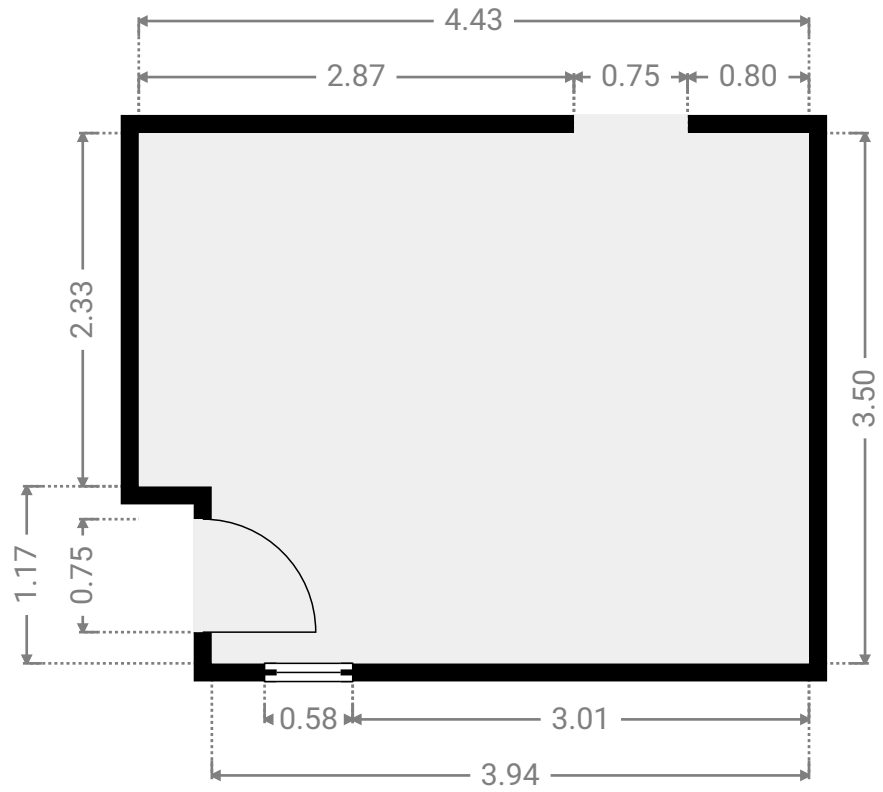
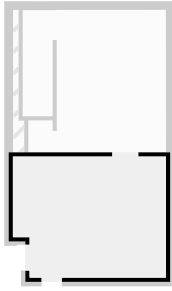

▼ Treppenhaus
Kellergeschoss

BREITE: 0.86 m · LÄNGE: 3.07 m
BEREICH: 2.65 m² · UMFANG: 7.86 m

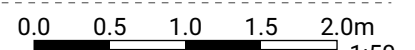
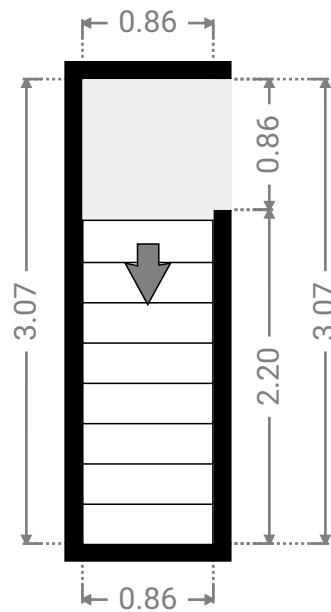
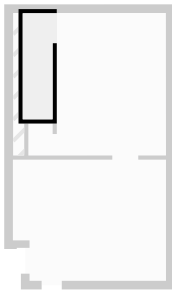

▼ Erdgeschoss

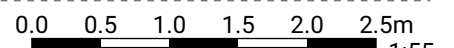
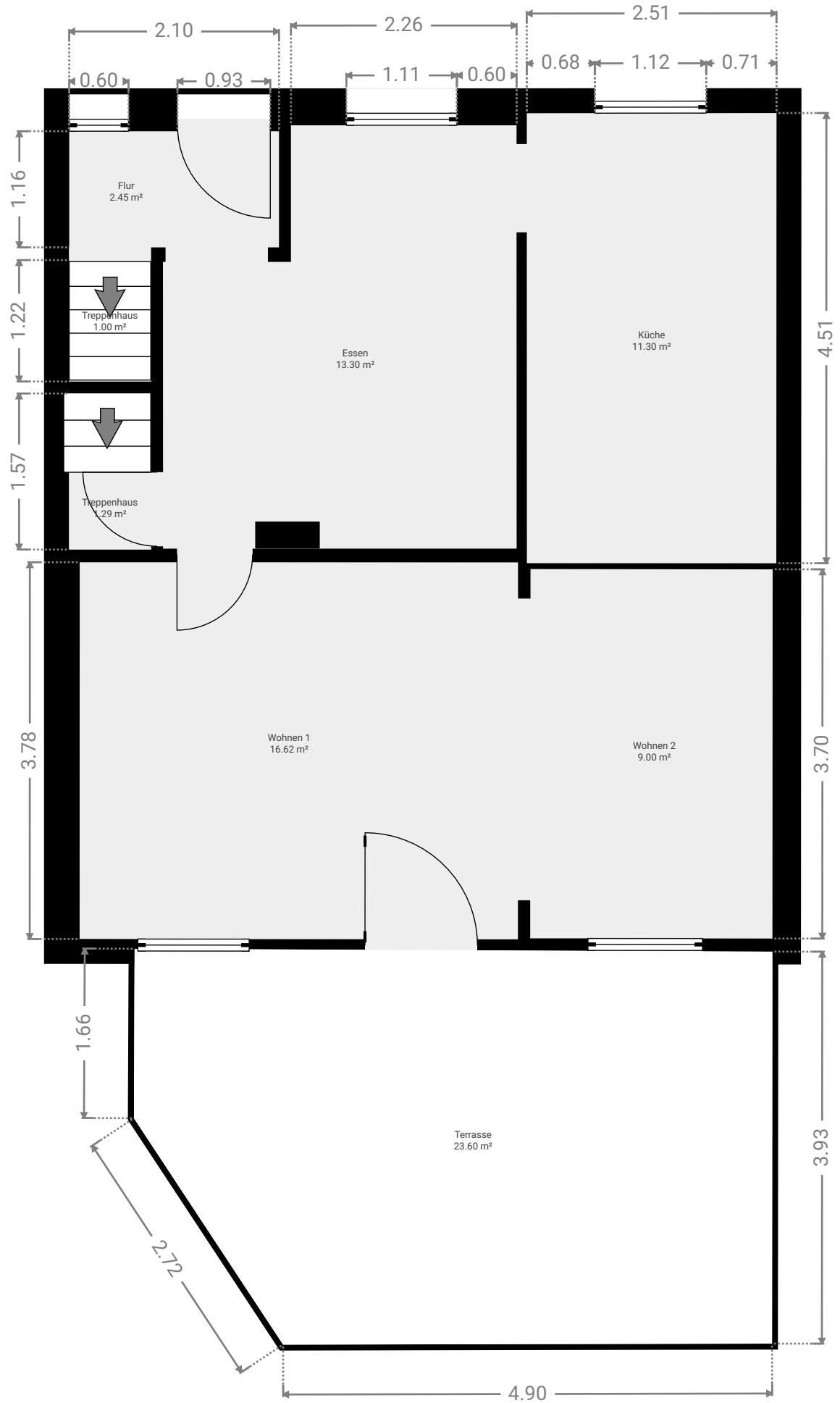

1:55

▼ **Essen**
Erdgeschoss

BREITE: 3.55 m • LÄNGE: 4.25 m
BEREICH: 13.30 m² • UMFANG: 15.59 m

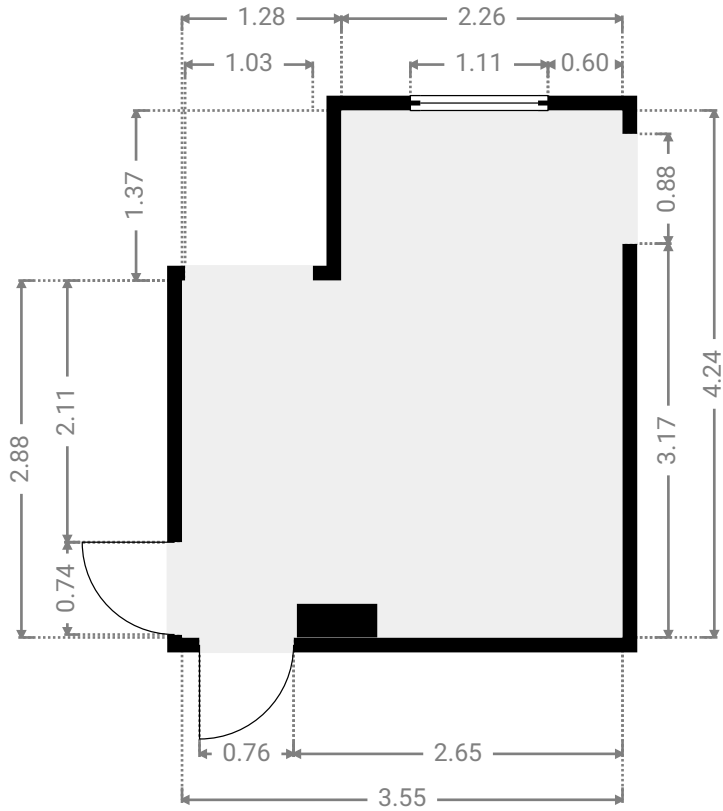
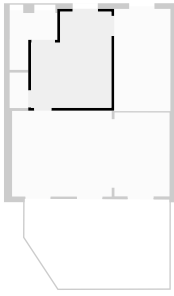

▼ **Flur**
Erdgeschoss

BREITE: 2.10 m • LÄNGE: 1.16 m
BEREICH: 2.45 m² • UMFANG: 6.54 m

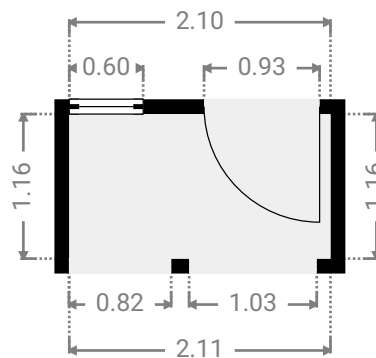
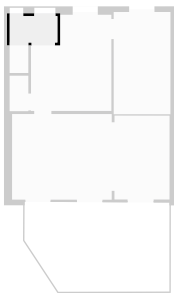

▼ **Küche**
Erdgeschoss

BREITE: 2.51 m • LÄNGE: 4.51 m
BEREICH: 11.30 m² • UMFANG: 14.03 m

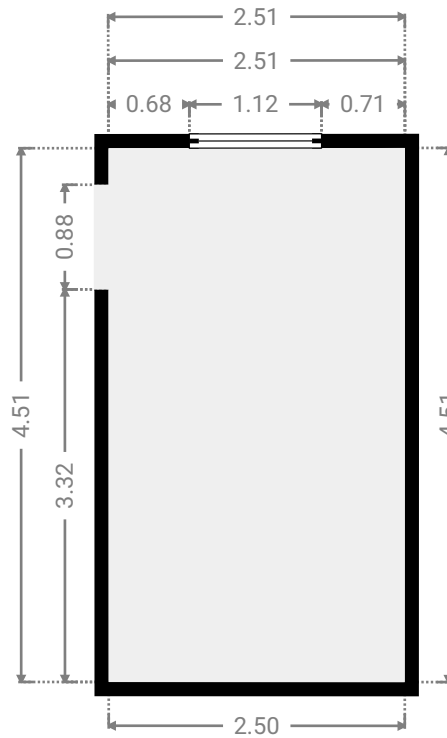
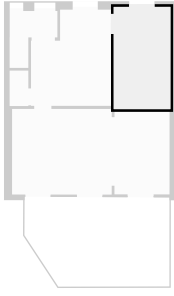

▼ **Terrasse**
Erdgeschoss

BREITE: 6.41 m • LÄNGE: 3.96 m
BEREICH: 23.60 m² • UMFANG: 19.65 m

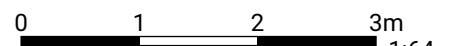
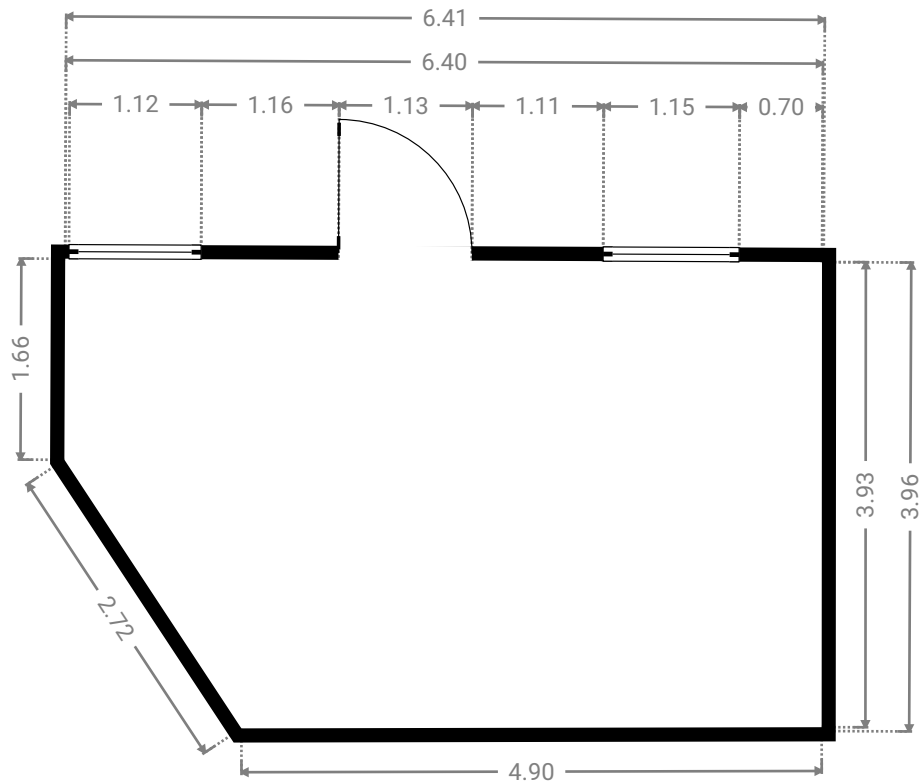
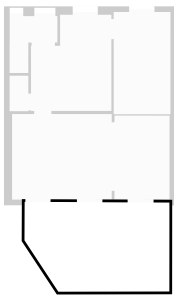

▼ **Treppenhaus**
Erdgeschoss

BREITE: 0.82 m • LÄNGE: 1.57 m
BEREICH: 1.29 m² • UMFANG: 4.78 m

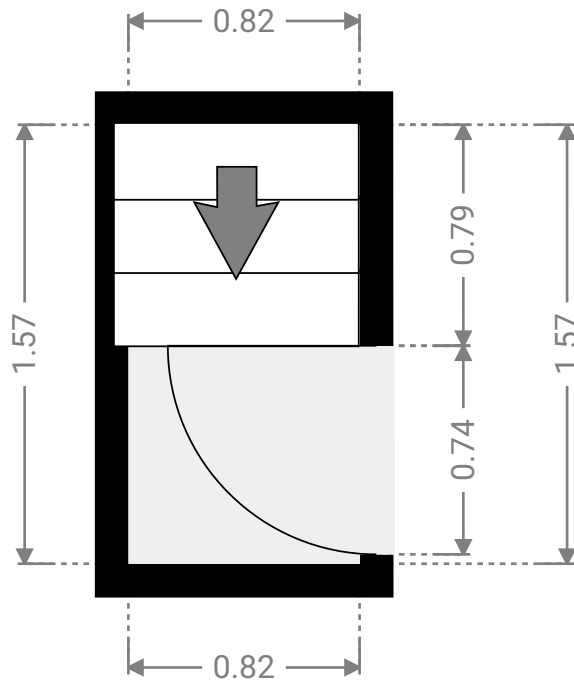
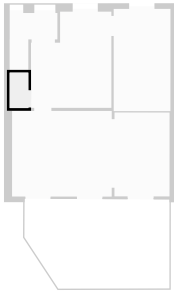

▼ **Treppenhaus**
Erdgeschoss

BREITE: 0.82 m • LÄNGE: 1.22 m
BEREICH: 1.00 m² • UMFANG: 4.08 m

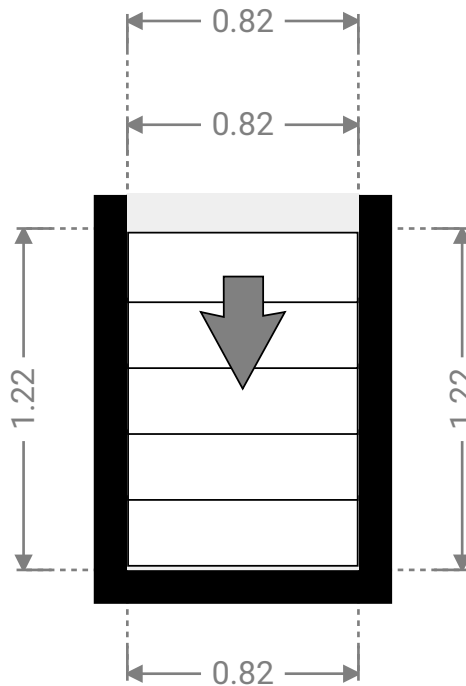
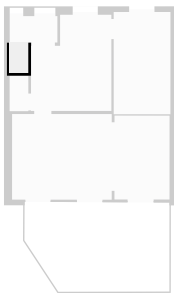

▼ **Wohnen 1**
Erdgeschoss

BREITE: 4.40 m • LÄNGE: 3.78 m
BEREICH: 16.62 m² • UMFANG: 16.35 m

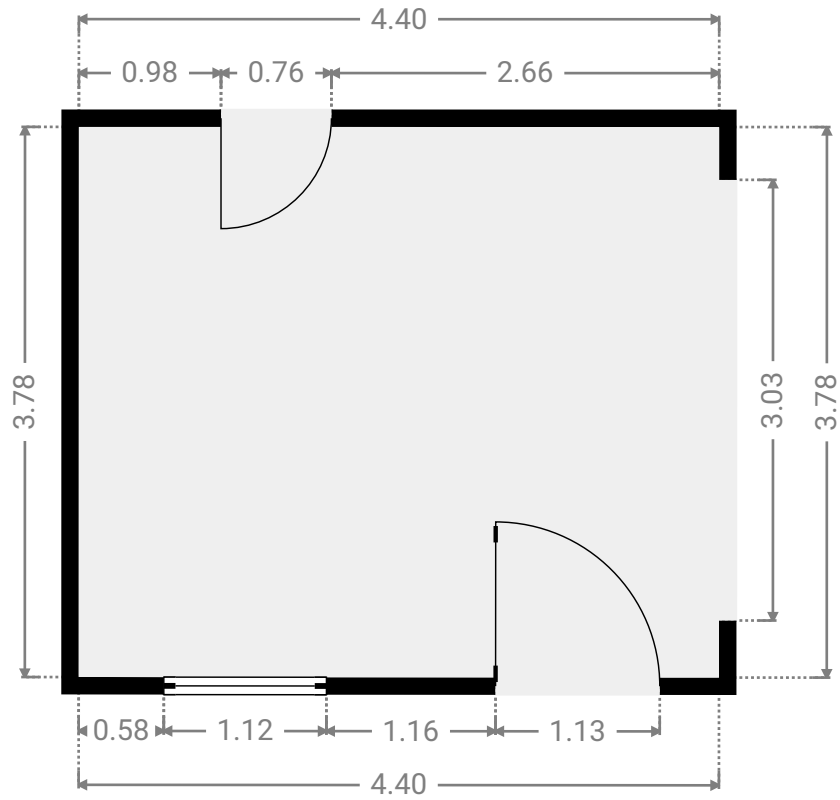
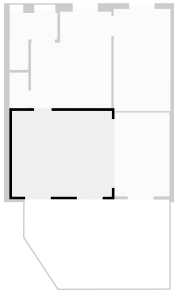

▼ **Wohnen 2**
Erdgeschoss

BREITE: 2.43 m • LÄNGE: 3.70 m
BEREICH: 9.00 m² • UMFANG: 12.27 m

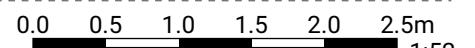
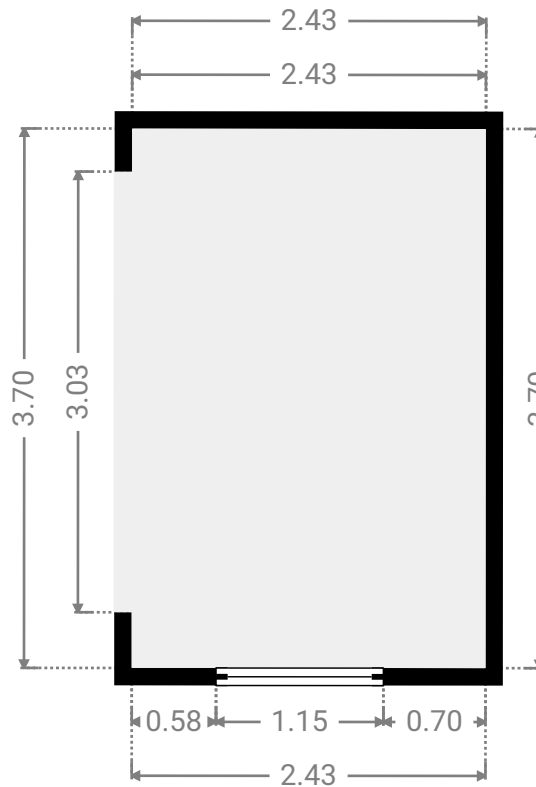
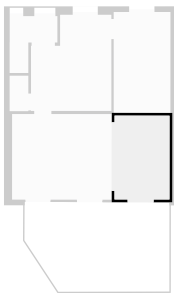

▼ 1. Stock

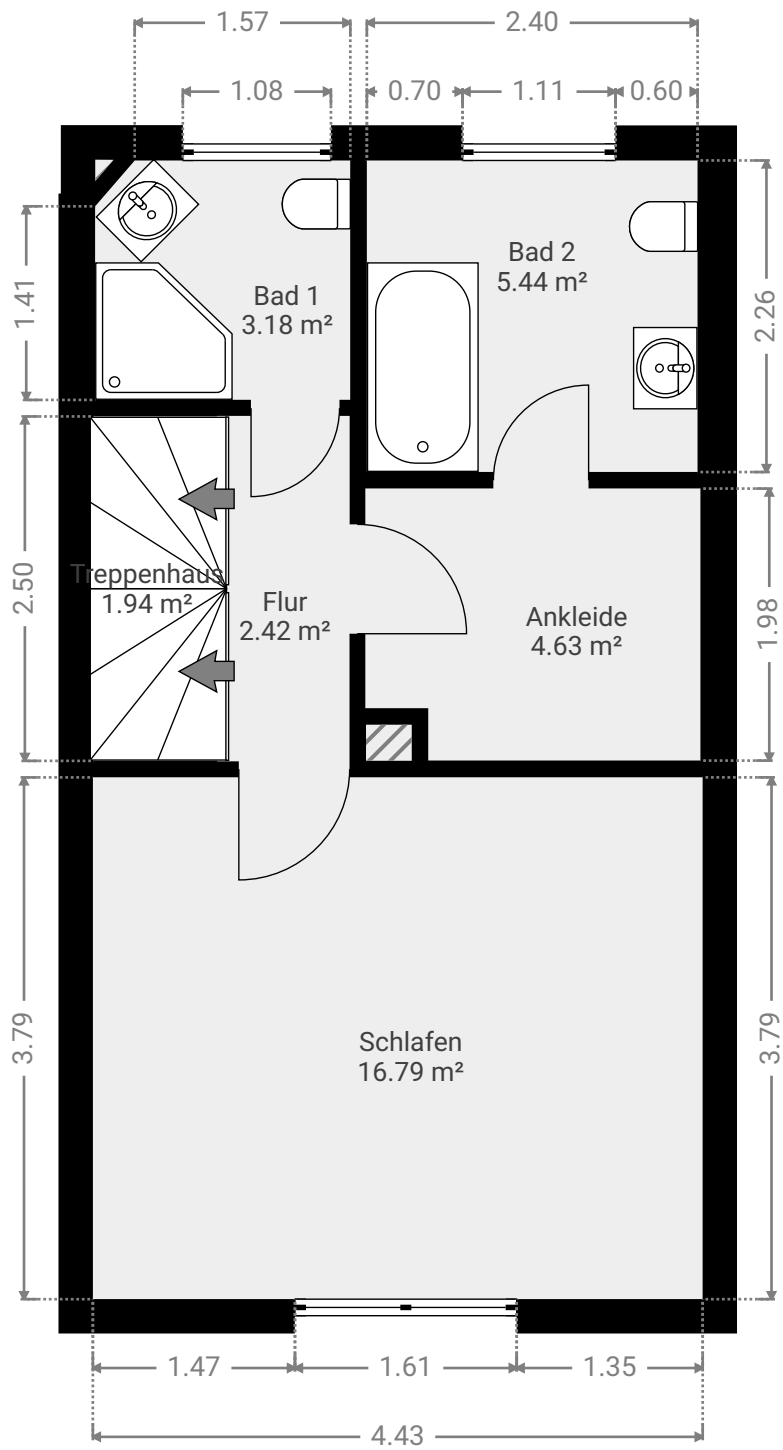

▼ **Ankleide**
1. Stock

BREITE: 2.43 m • LÄNGE: 1.98 m
BEREICH: 4.63 m² • UMFANG: 8.82 m

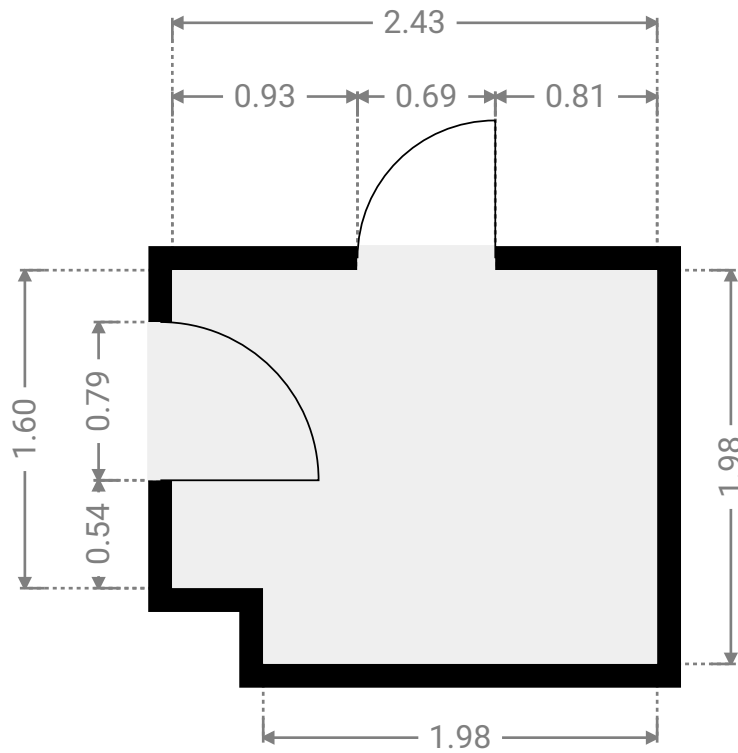
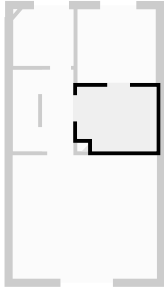

▼ **Bad 1**
1. Stock

BREITE: 1.85 m • LÄNGE: 1.74 m
BEREICH: 3.18 m² • UMFANG: 7.01 m

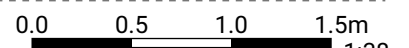
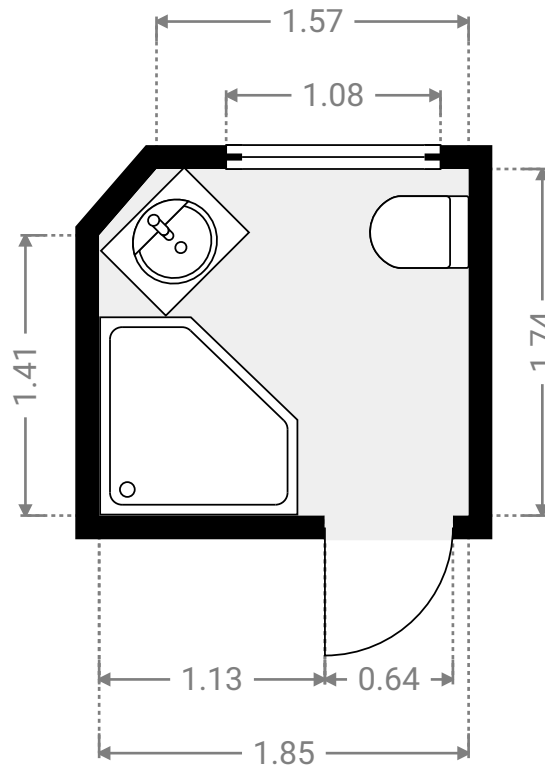
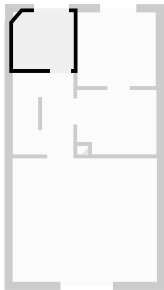

▼ **Bad 2**
1. Stock

BREITE: 2.40 m • LÄNGE: 2.26 m
BEREICH: 5.44 m² • UMFANG: 9.33 m

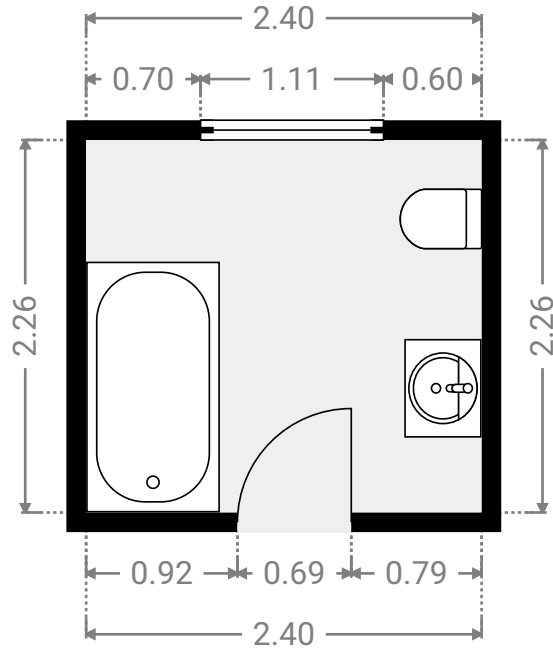
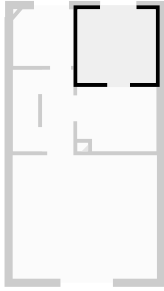

▼ **Flur**
1. Stock

BREITE: 0.96 m • LÄNGE: 2.51 m
BEREICH: 2.42 m² • UMFANG: 6.95 m

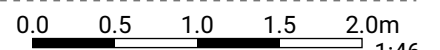
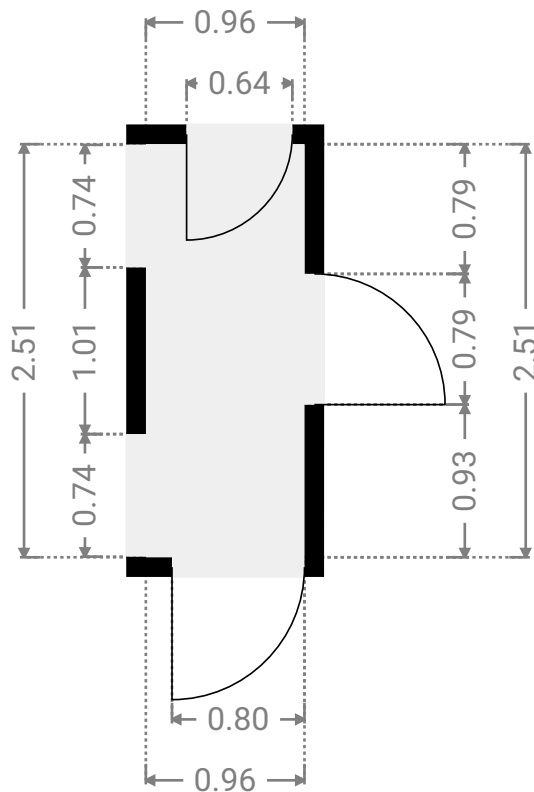
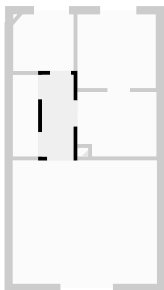

▼ **Schlafen**
1. Stock

BREITE: 4.43 m • LÄNGE: 3.79 m
BEREICH: 16.79 m² • UMFANG: 16.44 m

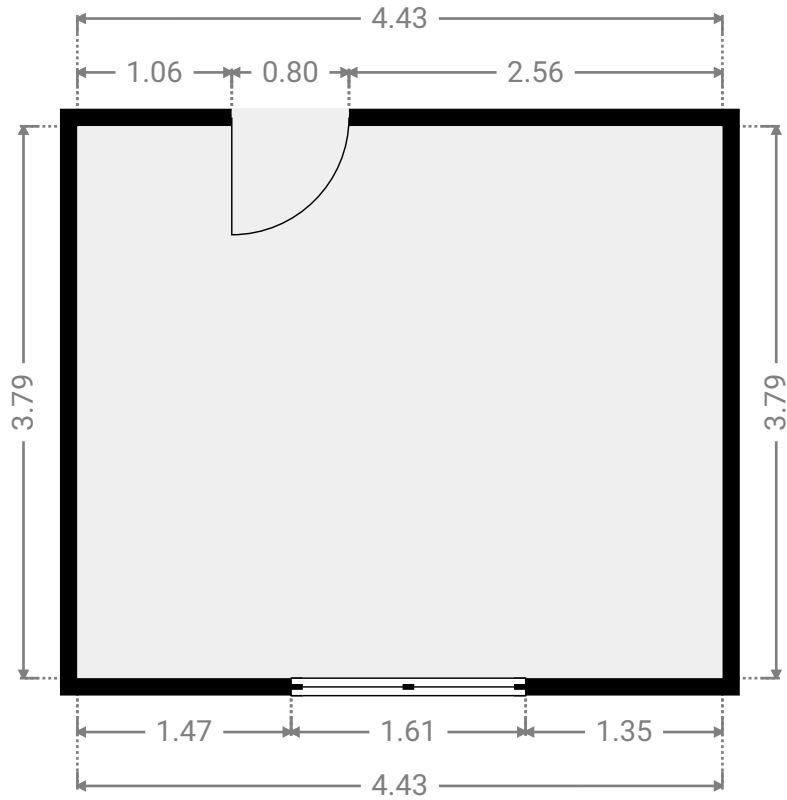
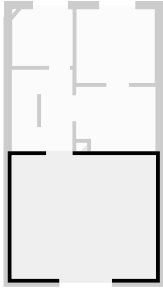

▼ **Treppenhaus**
1. Stock

BREITE: 0.78 m • LÄNGE: 2.50 m
BEREICH: 1.94 m² • UMFANG: 6.55 m

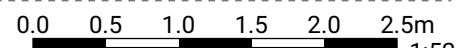
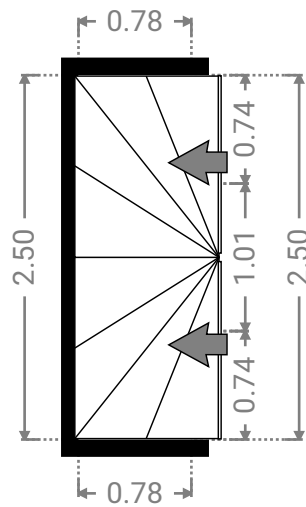
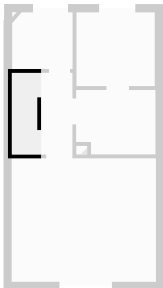

▼ Dachgeschoss

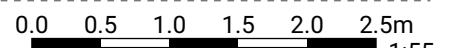
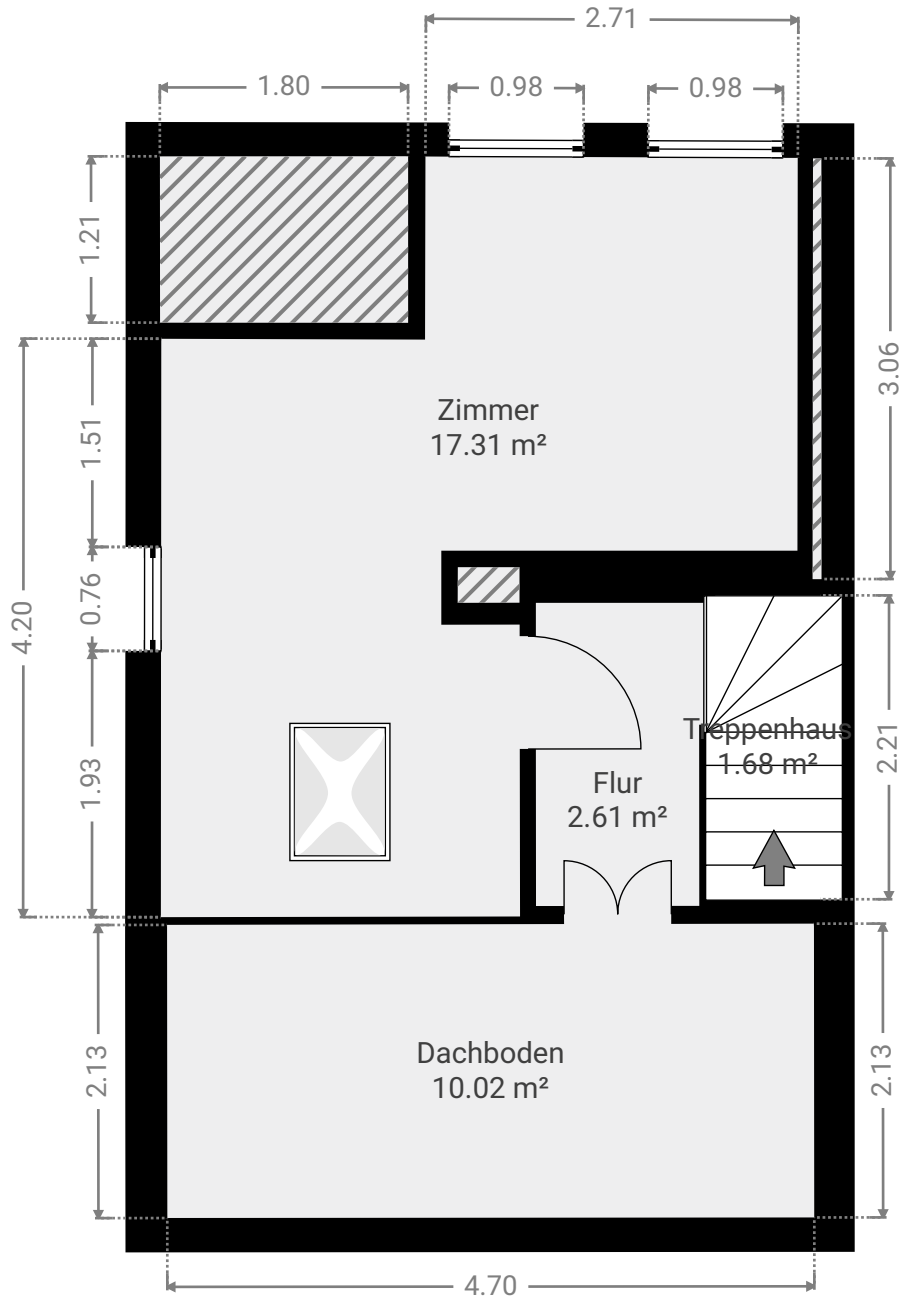

▼ **Dachboden**
Dachgeschoss

BREITE: 4.70 m • LÄNGE: 2.13 m
BEREICH: 10.02 m² • UMFANG: 13.66 m

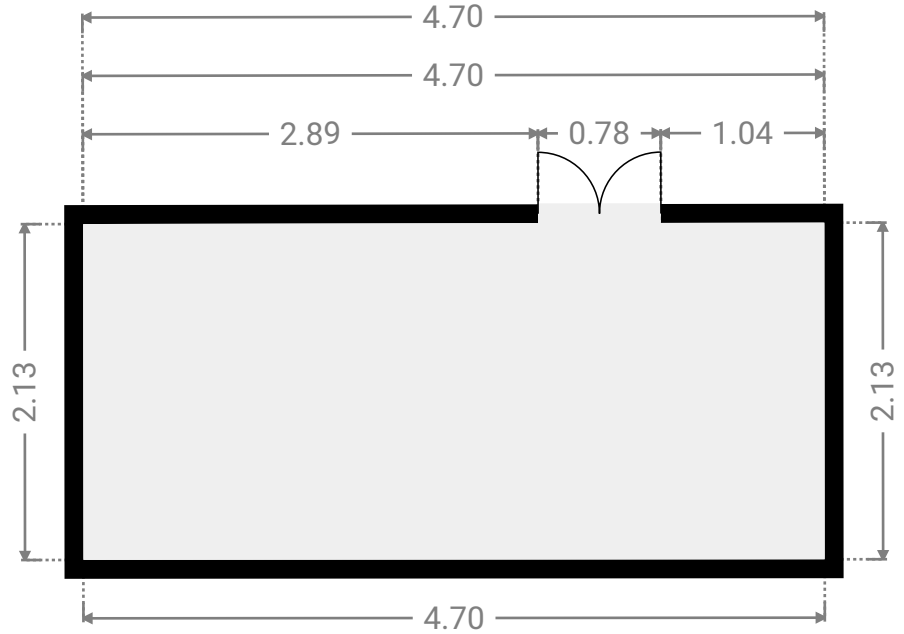
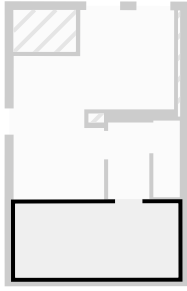

▼ **Flur**
Dachgeschoss

BREITE: 1.19 m • LÄNGE: 2.20 m
BEREICH: 2.61 m² • UMFANG: 6.78 m

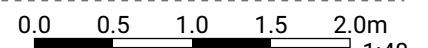
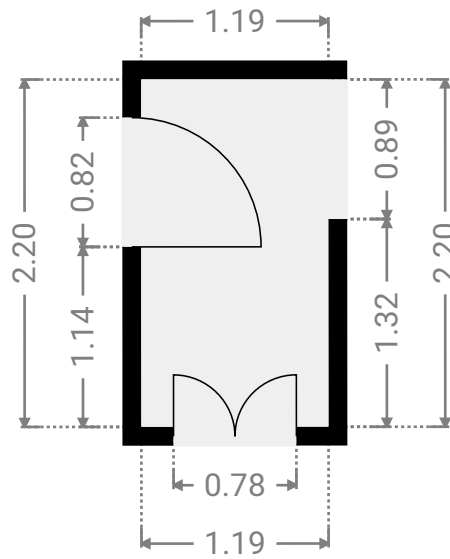
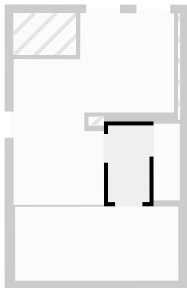

▼ **Treppenhaus**
Dachgeschoss

BREITE: 0.76 m • LÄNGE: 2.21 m
BEREICH: 1.68 m² • UMFANG: 5.94 m

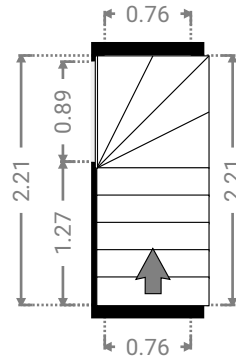
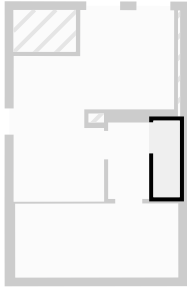

▼ **Zimmer**
Dachgeschoss

BREITE: 4.63 m • LÄNGE: 5.53 m
BEREICH: 17.31 m² • UMFANG: 21.43 m

